

DH-CA-FW191J

800TVL Day/Night Waterproof IR Camera



Features

- > 1/3" 1.3Mega HDIS
- > High resolution of 800TVL(Color)
- > Day/Night(ICR), ATW, AGC, BLC
- > 8mm fixed lens (3.6mm, 6mm,12mm,16mm optional)
- > Max. IR LEDs length 50m, Smart IR
- > IP66, DC12V

DH-CA-FW191J

Technical Specifications

| Model | DH-CA-FW191JP | DH-CA-FW191JN |
|------------------------|--|----------------|
| Camera | | |
| Image Sensor | 1/3" 1.3Mega HDIS | |
| Effective Pixels | 1280(H)×960(V) | |
| Horizontal Resolution | 800TVL | |
| Electronic Shutter | 4/25s~1/45,000s | 4/30~1/54,000s |
| Synchronization | Internal | |
| Min. Illumination | 0.01Lux@F1.2(0Lux IR LED on) | |
| S/N Ratio | >65dB(AGC Off) | |
| Video Output | 1Vp-p Composite Output (75Ω/BNC) | |
| Camera Features | | |
| Max. IR LEDs Length | 50m, Smart IR | |
| Day/Night | Auto(ICR) / Color / B/W | |
| Backlight Compensation | BLC | |
| White Balance | Auto | |
| Gain Control | Auto | |
| Noise Reduction | 3D | |
| Lens | | |
| Focal length | 8mm fixed lens (3.6mm, 6mm,12mm,16mm optional) | |
| Mount Type | M12 | |
| General | | |
| Power Supply | DC12V±10% | |
| Power Consumption | Max 7W | |
| Working Environment | -40°C~+60°C / 20%~80%RH | |
| Ingress Protection | IP66 | |
| Dimensions(W×D×H) | 200.2mm×89.1mm×80.4mm | |
| Weight | 450g | |

DH-CA-FW191J

Dimensions (mm)

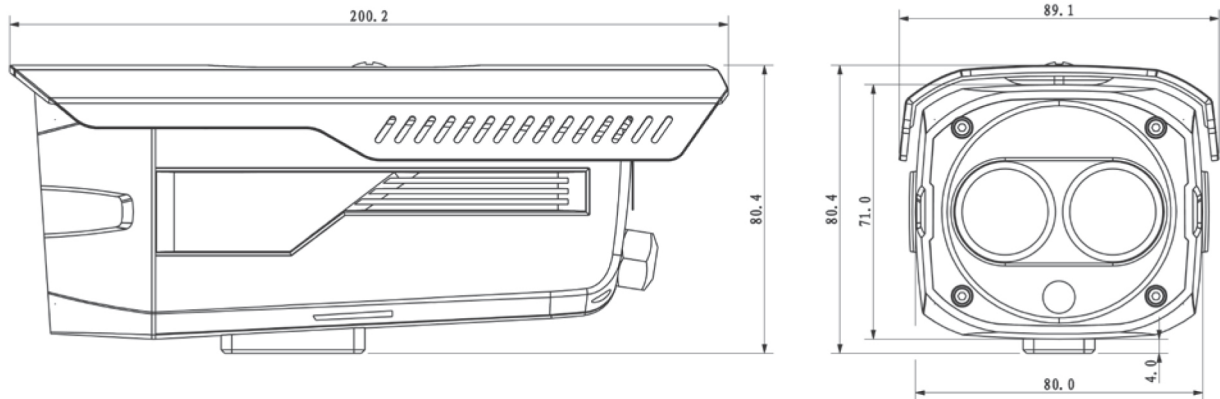

Main Office Address:(Cebu City)
Ground Floor SUGBUTEL Bldg. S.Osmeña Blvd.
Corner Road East North Reclamation Area
(Near SM City) Cebu, 6000 Philippines
Contact:
Tel#: (032) 266 - 7122
Email: sales@gigaworkz.net

Cagayan De Oro Branch
2nd Floor ORO Holiday Appliance Plaza Bldg.
Osmeña Extension St.
(Beside Capitol University - Back Gate)
Cagayan De Oro City, 9000 Philippines
Contact:
Tel#: (088) 880 - 1821
Email: salescagayan@gigaworkz.net

Metro Manila Branch
Suite 815, Ortigas Bldg.,
Ortigas Avenue(In-front of Meralco Bldg.)
Pasig City, Philippines
Contact:
Tel #: (02) 632 - 0720
Email: salesmanila@gigaworkz.net